

# User guide

**Printing terminal KT-V510**

---

Copyrights © 2023 Kingtop Corp. All rights reserved. The information contained in this document is subject to change without notice and should not be construed as a commitment by Kingtop Corp.

## **Patents and Licenses**

For a complete list of all Kingtop Corp. patents, visit <https://www.kingtoptec.com/contact>

## **Software License**

Proprietary Rights Provisions:

The software drivers provided with this product are copyrighted by Kingtop Corp. and/or Kingtop Corp.' suppliers. Although copyrighted, the software drivers are unpublished and embody valuable trade secrets proprietary to Kingtop Corp. and/or Kingtop Corp. suppliers. The disassembly, decompilation, and/or Reverse Engineering of the software drivers for any purpose is strictly prohibited by international law. The copying of the software drivers, except for a reasonable number of back-up copies is strictly prohibited by international law. It is forbidden by international law to provide access to the software drivers to any person for any purpose other than processing the internal data for the intended use of the software drivers.

## **Trademarks and Service Marks**

Kingtop Corp. is a trademark of Kingtop Corp., and the other trademarks, logos, and service marks (collectively the "Trademarks") used in this user manual are the property of Kingtop Corp. or their respective owners. Nothing contained in this user manual should be construed as granting by implication, estoppel, or otherwise, a license or right of use of Kingtop Corp. or any other Trademark displayed in this user manual without the written permission of Kingtop Corp. or its respective owners.

- Kingtop Corp., and the Kingtop Corp. logo are all trademarks of Kingtop Corp.

The names of actual companies and products mentioned in this user manual may be the trademarks of their respective owners.

---

# Contents

1. About Your printing Terminal .....	- 1 -
Front view .....	- 1 -
Back view .....	- 2 -
Side view .....	- 3 -
2. Printing Instructions .....	- 4 -
Printing tips .....	- 4 -
System pre-production software list .....	- 4 -
3. Precautions .....	- 5 -
Safety Warning .....	- 5 -
Important safety instructions .....	- 5 -
Suggestions .....	- 5 -
Declaration .....	- 6 -
Disclaimer .....	- 6 -
4. Proper Battery Use and Disposal .....	- 6 -
5. Limited Warranty and liability .....	- 7 -
6. Package Contents .....	- 8 -

# 1. About Your printing Terminal

## Front view

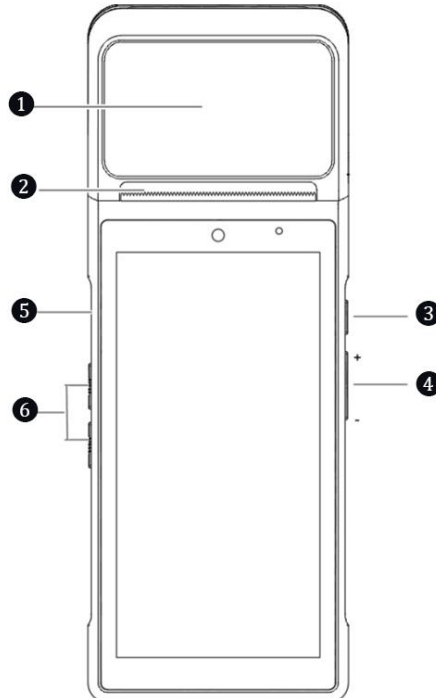

**① NFC reader** —— For Proximity card, membership card

**② Printer** —— Printing documents in power-on mode

**③ Power button**—— Short press and Long press

**Short press:** light up the screen, lock the screen

**Long press:** In the off state, press and hold for 2~3 seconds to turn on the phone.

Press and hold for 2~3 seconds to turn off or restart.

In the dead state, press and hold for 11 seconds to restart automatically.

**④ Volume keys**—— Adjust the volume level (the button can be set as a quick swipe key, which requires application support).

**⑤ Type-C** —— For charge devices and for developer debugging.

**⑥ Soft keys** —— To help user to complete various operations quickly.

## Back view

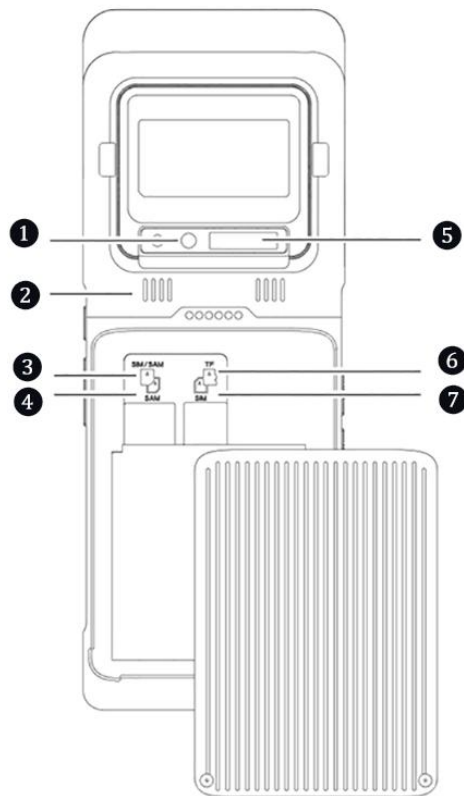

- ❶ Camera —— Support for taking pictures and 1D/2D quick scan.
- ❷ Speaker —— Remind merchants of each transaction in a timely manner
- ❸ SIM Slot

**Note:** When inserting or removing the SIM card, please make sure the machine is off, as plugging and unplugging in the on state may cause the machine to malfunction.

- ❹ PSAM Slot —— Used to insert encrypted PSAM CPU card.
- ❺ QR code reader——Used to read product barcodes and cell phone payment codes.
- ❻ TF Slot
- ❼ SIM Slot

Side view

How to Put Thermal Paper Roll Correctly?

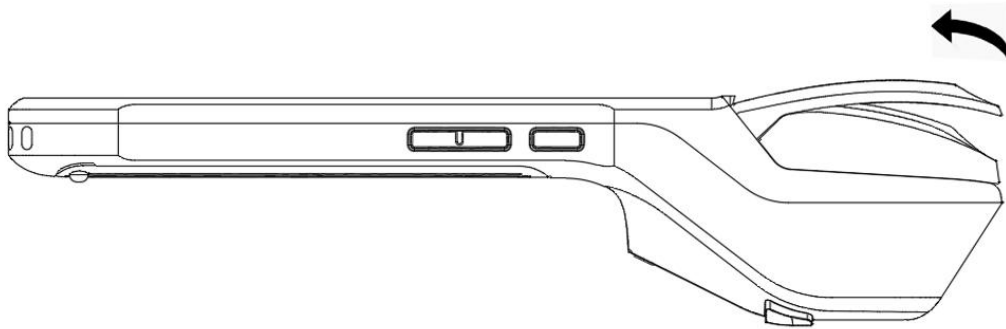

Figure 1-1

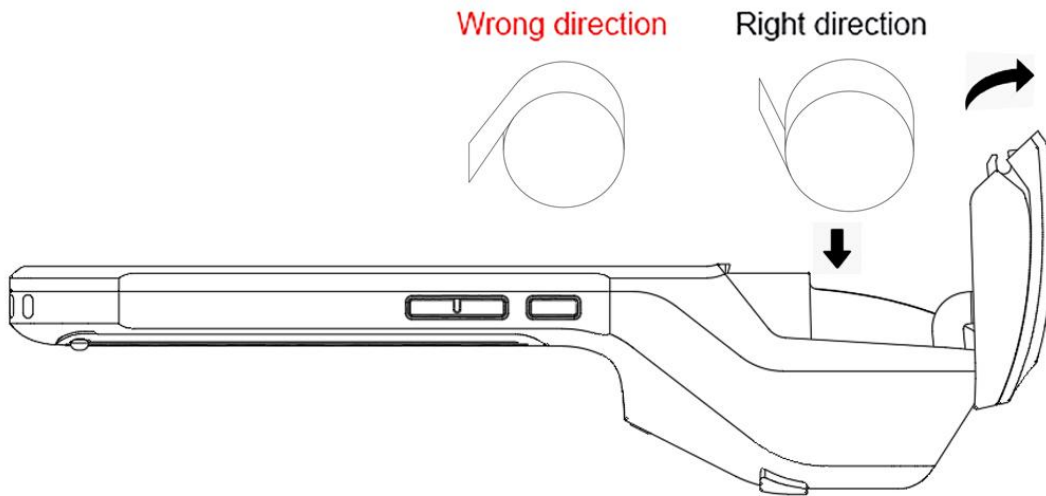

Figure 1-2

---

## 2. Printing Instructions

### Printing tips

- This machine supports 58mm thermal paper,  $57\pm 0.5\text{mm} \times 40\text{mm}$ .
- Please open the paper compartment (shown in the illustration) by opening the cover handle, do not force the paper to prevent the print head gear from wearing out.
- Place the paper in the paper compartment correctly in the direction shown in the figure, and pull out part of the paper to the outside of the cutter (Figure 1-1).
- Cover the paper compartment cover, the paper installation is complete figure (Figure 1-2).

**Note:** If the print content is blank, please check if the paper roll is placed in the opposite direction.

### System pre-production software list

1. Function key customization, BaseService, custom services (wallpaper, boot animation)
2. Developer's Guide (debugging assistant) , User's Guide, boot guide, remote assistance
3. How to check the above software details: select "**Settings->Applications**", select the corresponding software name to view the information.
4. Software uninstall method: select "**Settings->Applications->Manage Applications->Uninstall**" to uninstall the application, or long press the icon and drag it to the trash to uninstall.

---

## 3. Precautions

### Safety Warning

Please insert the AC plug into the AC outlet corresponding to the marked input on the accessory power adapter

This is a Class A product. In living environments, this product may cause radio interference.

In this case, the user may be required to take practical measures against interference.

- Use only the battery supplied with the unit.
- Do not replace the battery when explosive gases are present.
- Do not charge in hazardous locations.

### Important safety instructions

- Avoid installation or use during lightning, otherwise there is a risk of being struck by lightning.
- When you find abnormal smell, overheating or smoke, please cut off the power immediately.
- Do not touch the tear-off knife as it is sharp!
- When you find residual glue on the label print head, you can do the following maintenance.
- The device will be turned off, use cotton swabs or non-woven dipped in 75% concentration of alcohol wipe the print head, wait for the alcohol to dry and then turn on again.

**Note:** Do not use hard objects or sharp objects, otherwise it will damage the print head.

### Suggestions

- Do not use in extreme cold or hot environments, such as near a fire or a lit cigarette.
- Do not drop, throw or bend the printer.
- Use in a clean and dust-free environment to avoid small objects falling into the terminal.
- Do not use in the vicinity of medical equipment without permission.



---

## Declaration

Our company is not responsible for the following actions

-Damage caused by not using and maintaining the device under the conditions described in this guide.

-For damage or problems caused by options or consumables (other than the original or approved products provided by the Company).

(No modification or change of the product is authorized without our consent)

The operating system of this product supports official system updates. If the user brushes a third-party ROM system or modifies the system files by cracking, it may lead to system instability, as well as security risks and security threats.

## Disclaimer

Due to the update of the product, some details of this document may not match the product, please refer to the actual product, the interpretation of this document belongs to our company. We reserve the right to modify this manual without prior notice.

## 4. Proper Battery Use and Disposal

**IMPORTANT** In event of a battery leak:

- *Do not allow the liquid to come in contact with the skin or the eyes. If contact has been made, wash the affected area with large amounts of water and seek medical advice.*
- *Seek medical advice immediately if a battery has been swallowed.*
- *Communicate the appropriate steps to be taken if a hazard occurs. Due to the transmission and reception properties of wireless communications, data occasionally can be lost or delayed.*
- Please review the following guidelines for safe and responsible battery use.
- Do not disassemble or open, crush, bend or deform, puncture, or shred.
- Do not modify or re-manufacture, attempt to insert a foreign object into the battery, immerse

---

or expose to water or other liquids, or expose to fire, explosion, or other hazard.

- Only use the battery for the system for which it was specified.
- Only use the battery with a charging system that has been qualified with the system per this standard. Use of an unqualified battery or charger may present a risk of fire, explosion, leakage, or other hazard.
- Do not short circuit a battery or allow a metallic or conductive object to contact the battery terminals.
- Replace the battery only with another battery that has been qualified with the system per this standard. Use of an unqualified battery may present a risk of fire, explosion, leakage, or other hazard.
- Promptly dispose of used batteries in accordance with local regulations.
- Battery usage by children should be supervised.
- Avoid dropping the printing terminal or battery. If the printing terminal or the battery is dropped, especially on a hard surface, and the user suspects damage, take it to a service center for inspection.
- Improper battery use may result in a fire, explosion, or other hazard.

## 5. Limited Warranty and liability

Kingtop Corp. warrants for the 12-month period immediately following receipt of the Product by Purchaser that the Product will be free from defects in material and workmanship under normal use.

THESE WARRANTIES ARE EXPRESSLY IN LIEU OF ALL OTHER WARRANTIES, EXPRESS OR IMPLIED, INCLUDING, WITHOUT LIMITATION, ALL IMPLIED WARRANTIES OF MERCHANTABILITY AND FITNESS FOR A PARTICULAR PURPOSE.

The exclusive remedy for a claim under this warranty shall be limited to the repair or replacement, at KINGTOP CORP' option, of defective or non-conforming materials, parts or components. The foregoing warranties do not extend to

(I) non conformities, defects or errors in the Products due to accident, abuse, misuse or negligent use of the Products or use in other than a normal and customary manner, environmental

conditions not conforming to KINGTOP CORP' specification, of failure to follow prescribed installation, operating and maintenance procedures,

(II) defects, errors or nonconformities in the Product due to modifications, alterations, additions or changes not made in accordance with KINGTOP CORP' specifications or authorized by KINGTOP CORP,

(III) normal wear and tear,

(IV) damage caused by force of nature or act of any third person,

(V) shipping damage,

(VI) service or repair of Product by the purchaser without prior written consent from KINGTOP CORP,

(VII) products designated by KINGTOP CORP as beta site test samples, experimental, developmental, reproduction, sample, incomplete or out of specification Products, or

(VIII) returned products if the original identification marks have been removed or altered.

## 6. Package Contents

Please carefully open the packaging of the printing terminal and count the accessories according to the table below. It is recommended that you keep the packaging and packaging materials:

No.	Configure	Quantity
1	Printing terminal KT-V510	1 pcs
2	User guide	1 pcs
3	Power adapter	1 pcs
4	Type-C cable	1 pcs
5	Packing box	1 pcs
6	Warranty card	1 pcs

